



Sumitomo Electric Wiring Systems, Inc.

Part Identification and Labeling Requirements

1.0 INTRODUCTION

These specifications provide guidelines for printing and applying a Shipping/Parts Identification label.

⊗ *Note: In this document, the word “must” indicates a requirement and the word “should” indicates a recommendation. Also Exhibits 1, 2, 3, 4 are provided for Data Area reference only and must not be used to refer to the actual dimensions of the labels. Please follow the actual dimensions mentioned specifically under each category while printing labels.*

2.0 DEFINITIONS

Item - A single part or material purchased.

Pack, Package or Load - A unit that provides protection and containment of items plus ease of handling by manual or mechanical means. Examples of containers or packs that normally are disposable include bags, cartons, cartons on pallets and pallet boxes. Examples of containers or packs which are returnable include bins (wire mesh or solid sides and ends), racks (plain or with special dunnage), racks with wire mesh sides and ends, tubs, and drums.

Standard Quantity Pack - A pack which always contains the same quantity of like items.

Non-Standard Quantity Pack - A pack which contains variable quantities of like items.

Common Item Pack - A pack which contains all like items, i.e., same part/item numbers.

Mixed Item Pack - A pack containing items with different part/item numbers.

Multiple Pack - A pack containing smaller packages (subpacks) of items.

Subpack - One of the smaller packs (which may be a standard quantity or non-standard quantity pack) that make up a larger multiple pack.

Shipping Pack - A pack used for shipping items from one plant to another and can be any of the pack described above.

Label - A card, strip of paper, etc. marked and attached to an object to indicate its nature, contents, ownership, destination, etc.

Tag - A label that is hung from an object, usually with a wire placed through a reinforced eyelet in the label/tag.

Shipping/Parts Identification Label - A label used to identify the contents of a shipping pack.

Master Label - A label used to identify and summarize the total contents of a multiple pack

Mixed Load Label - A label used to designate mixed item, shipping packs.

3.0 SIZE AND MATERIALS

3.1 LABEL SIZE

- ◆ The minimum label size will be determined by the packaging style and size. Wherever possible SEWS would like the label size to be 4.0" (102mm) high by 6.0" (150mm) wide. See Exhibit 1. If the above size label cannot be affixed to the package/container because of container size or design, you must try the second preferred label size namely a 4" x 2" size label with the minimum data contents bar coded as shown in Exhibit 2.
- ◆ The label paper must be white in color with black printing.
- ◆ The label paper need not be of adhesive type as long as adherence to the package substrate is assured and application is wrinkle-free.
- ◆ Besides the above mentioned two sizes of labels, special labels shall be provided by the suppliers according to the arrangement with SEWS. For a detail discussion of these, please see Section 7.

3.2 TAGS (HAND TAGS)

- ◆ The tag size must be one of the two sizes as described in Section 3.1 (4x6 or 4x2) plus the material necessary to add a reinforced eyelet. The tag must be durable enough to assure readability at its destination.

 **Sumitomo Electric Wiring Systems, Inc.**
Part Identification and Labeling Requirements

Exhibit 1 – A Sample 4” x 6” SEWS Parts Identification Label





PART NO. (P) AVSS		125	
			
QUANTITY (Q) 30000	M	COLOR (C) B - Y	
SUPPLIER WKRF		PART DESCRIPTION THIS IS A WIRE SUPPLIER PART#	ORDER NO. (A) 123456 
SERIAL (S) ABCD000005			LOT NO.
XYZ COMPANY INC. ANYTOWN, KY 42102 U.S.A			Printed On AUG 13 1996

Exhibit 2 – A Sample 4” x 2” SEWS Parts Identification Label

PART NO. (P) 1234567890123456			
			
QUANTITY (Q) 300000	M	COLOR (C) BG-LY	
SERIAL (S) WK96320001		ORDER NO. (A) 645103	
			
XYZ COMPANY INC. ANYTOWN, KY 42102 U.S.A			

4.0 DATA AREA CHARACTERISTICS

The part number, color code (where applicable) quantity, supplier code, label serial number and purchase order number *must* be included on each label and must be displayed in both human readable characters and bar code symbols.

4.1 DATA AREAS AND TITLES

There are 6 data areas for each label: Part Number, Color Code, Quantity, Supplier Code, Serial Number, and Purchase Order Number. Each data area must be separated by thin lines and must contain its title in the upper left-hand corner, as shown in the Exhibit. Outer border lines are not required. Titles should be printed 0.06” (1.5mm) high letters wherever possible. The data area titles are *Part No., Color, Quantity, Supplier, Serial, and Order No.*

4.2 DATA IDENTIFIER CODES

A Data identifier code in the first position following the start code of the bar code symbols must be used to identify the information to follow. This character is not to be included in the human readable line, but is shown in human readable characters under the title for the appropriate data area. See Exhibit 1.

Using additional bar code symbols, other than the one shown on the Exhibit 1, on shipping packages is not encouraged, but may be allowed as long as each additional bar code symbol is used with a data identifier. The following identifier codes are assigned for the different types of data:

- P** - SEWS Part Number
- C** - Wire Color Code, if you are supplying wires.
- Q** - Quantity
- S** - Unique Serial Number – Shipping/ Parts Identification Label
- M** – Unique Serial Number – Master Label
- G** – Unique Serial Number – Mixed Load
- A** – Purchase Order Number

4.3 PART NUMBER AREA

The human readable part number characters must be bold and a minimum 0.5” (13mm) high. The bar code symbol of the part number must be directly below the human readable characters and must be a minimum 0.5” (13mm) high. The maximum length of any bar code symbol should not exceed 5.5” (140mm). The maximum length for the Part Number field is sixteen (16) alphanumeric characters plus the data identifier (P). If you supply wires, our system requires that the size of the wire start in position 9 of the part number unless the size is 4 digits (1000) or more than the size must start in position 8 of part number. Example: AVSS 050 Also there should not be any decimal points in the size such as 0.50 due to our system not recognizing these as part numbers.

The Part Number will be designated by SEWS and informed to supplier, in the SEWS Purchase Order Document.

4.3a COLOR CODE AREA (Applicable to Wire Suppliers Only)

If supplying wires to SEWS, the Color Code information must be provided in the Additional part number area. See Exhibit 1. The Color Code will follow the same standard as part number above. Example of SEWS Color Code: B – L, BR – B. If there are two colors on the wire and there is only one initial color (B) there must be a space after the B and before the – for our system to recognize this as an acceptable color.

The maximum length for the Color Code is five (5) alphabetic characters plus the data identifier (C).

The Color Code will be designated by SEWS and informed to supplier, in the SEWS Purchase Order Document.

4.4 QUANTITY AREA

The human readable quantity characters must be a minimum 0.5” (13mm) high. The bar code symbol for the quantity must be directly below the human readable characters and must be a minimum 0.5” (13mm) high. The maximum length for the quantity is six (6) numeric characters plus the data identifier (Q).

When the unit of measure is pieces, no notation is required. When the unit of measure is not pieces (e.g., pounds, pairs, feet, etc.), it should be noted in human readable form only. When used, the unit of measure abbreviations as defined in the ASC X12.3 Data Element Dictionary must be used. See Appendix A.

4.5 SUPPLIER NUMBER (Applicable to 4” x 6” size label suppliers)

If you are supplying a 4” x 6” size label, The human readable supplier number characters must be a minimum 0.5” (13mm) high. The Supplier Code need not be bar coded. The maximum length of the supplier number must be four (4) alphanumeric characters.

The Supplier code will be designated by SEWS and informed to supplier, in the SEWS Purchase Order Document.

4.6 SERIAL NUMBER AREA

The human readable serial number characters must be a minimum of 0.5” (13mm) high. The bar code symbol for the serial number must be directly below the human readable characters and must be a minimum 0.5” (13mm) high. The minimum and maximum length of the serial number must be ten (10) alphanumeric characters plus the data identifier (S). The serial number must be a unique number (not necessarily in sequential order) assigned by the supplier. Suppliers should avoid repeating serial numbers within any calendar year. Each shipping container or pack bearing a label must have a unique serial number. In this way each container, regardless of content or destination, can be differentiated from others. The supplier name, city, state and zip code must be directly below the bar code symbol and should be 0.1” (2.5mm) high.

4.7 PURCHASE ORDER AREA

This must be on the same line as the supplier number, to the right of it, after the description area. The human readable purchase order characters must be a minimum of 0.5" (13mm) high. The bar code symbol for the order number must be directly below the human readable characters and must be a minimum 0.5" (13mm) high. The maximum length of the order number must be six (6) alphanumeric characters plus the data identifier (A).

The Order Number will be designated by SEWS and informed to the supplier.

4.8 ADVANCED SHIPMENT NOTIFICATIONS (ASN)

The data contained on this label must be consistent with data transmitted in the advanced shipment notifications, if you are participating in EDI transactions with SEWS.

5.0 BAR CODE SYMBOLOGY

Bar codes must be the 3-of-9 (Code 39) type and must conform to the "Bar Code Symbology Standard for 3-of-9 Bar Codes" published by the Automotive Industry Action Group (AIAG-B-1) in addition to these symbology specifications, Sections 5.1 through 5.5 cover specific requirements for the Shipping/Parts Identifications Label.

5.1 CODE CONFIGURATION

The four (4) characters (\$, /, +, %) of the 3-of-9 symbology must not be used on the Shipping/Parts Identification Label, as this causes various scanning problems for SEWS.

5.2 CODE DENSITY AND DIMENSIONS

The bar heights must be a minimum of 0.5" (13mm). For each bar code symbol, the average width of the narrow elements must be within the range of .013 to 0.17 inches. The ratio of the nominal width of the wide elements to the nominal width of the narrow elements must be 3:1, with an allowable range of 2:8:1 to 3:2:1.

5.3 CHECK DIGITS

Check digits must not be added in the bar codes.

5.4 REFLECTIVITY AND CONTRAST

The printed bar code symbols must meet the reflectivity and contrast requirements, specified in Section 4.1 of AIAG-B1, at all electromagnetic wave lengths from B633 to B900 nanometers.

5.5 QUALITY ASSURANCE REQUIREMENTS

It is the responsibility of the supplier to provide bar coded labels that meet these specifications. Equipment is available to verify that bar code symbols meet these requirements. Use of statistical process control techniques to minimize printing variability is recommended.

6.0 LABEL LOCATION AND PROTECTION

6.1 LABEL LOCATION

Illustrations of the most common shipping packs and recommended label locations are shown on Exhibits 7a, 7b and 7c. In most cases two labels are specified. The bottom edge of the label should be parallel to the base of the package/container. To facilitate automatic reading of bar code symbols, the top edge of the label, where possible, should be 20” from the bottom of the container. Wraparound labels are acceptable as long as quiet zones are within specifications.

6.2 LABEL PROTECTION

Label protection against moisture, weathering, abrasion, etc., may be required in harsh environments and is encouraged wherever practical. Laminates, sprays, window envelopes, and clear plastic pouches are examples of possible protection methods. In choosing any protection method, care must be taken to assure that labels meet reflectivity and contrast requirements and can be scanned with contact and non-contact devices.

7.0 SPECIAL LABELS

While the above specifications will cover most situations, there will be circumstances where requirements will dictate special arrangements between SEWS and supplier. Two situations where special labels may be needed for better handling are multiple and mixed item packs. Section 7.1 and 7.2 outline recommended practices for these situations.

7.1 MULTIPLE, COMMON ITEM PACKS (Master Label)

A Master Label, as shown in Exhibit 2, should be used when the SEWS and supplier agree that the total contents of a multiple, common item pack should be identified. If all the subpacks of the multiple, common item pack originate from a single Purchase Order number, then a Master Label must be used to identify the total contents of the pack. Of course, each subpack of the multiple pack should be identified with a Master Label placed on the pack in such a manner that when the pack is broken apart the label is discarded (e.g., hang Master Label from banding or attach to stretch wrap).

At the top of this label, the heading “**MASTER LABEL**” should be printed in bold 1.0” (25.4mm) letters. The balance of the label format should conform to the specifications for the Shipping/Parts Identification Label except that the data identifier for the serial number must be “**M**” instead of “**S**”. The serial number, preceded by an “**M**” in the bar code form only, must be a unique number, not be repeated over the course of a year. The quantity on the master label must be the total in all the subpacks.

MASTER LABEL

PART NO. (P) AVSS 125F	
	
QUANTITY (Q) 300000 M	COLOR (C) B - L
	
SUPPLIER WKRF	PART DESCRIPTION THIS IS MASTER SUPPLIER PART#
	ORDER NO. (A) 6450001
	
SERIAL (M) MASTER00001	LOT NO.
	
XYZ COMPANY INC. ANYTOWN, KY 42102 U.S.A	Printed On AUG 13 1996

Exhibit 3 – Master Label

7.2 MIXED ITEM LOADS

Mixed item loads should have a label with the work “**MIXED LOAD**” in bold 1.0” (25.4mm) letters attached in a noticeable location. See Exhibit 3. Each subpack must be identified with a Shipping/Parts Identification Label. The supplier and serial numbers as specified in Sections 4.5 and 4.6 are included. One exception is that the data identifier for the serial number on the mixed load label must be “**G**” instead of “**S**”.

<h1>MIXED LOAD</h1>		
SUPPLIER WKRF		
SERIAL (G)	MIXED00001	
		
XYZ COMPANY INC. ANYTOWN, KY 42102 U.S.A		Printed On AUG 13 1996

Exhibit 4 – Mixed Load Label

EXHIBIT 7A

LABEL LOCATIONS ON VARIOUS SHIPPING PACKS

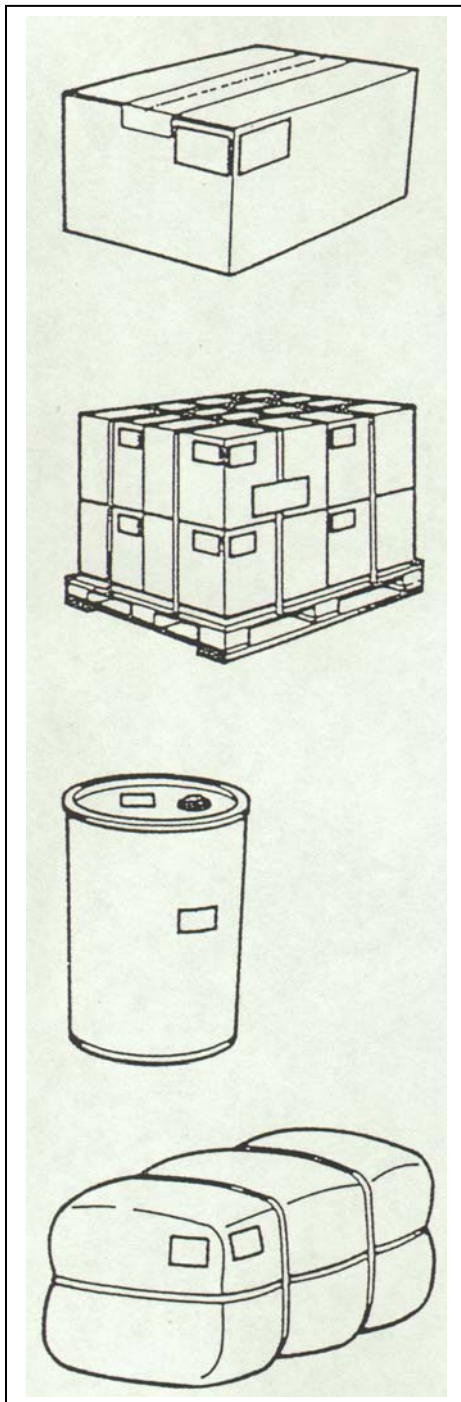

BOX OR CARTON

IDENTICAL LABELS SHOULD BE LOCATED ON TWO ADJACENT SIDES. (WRAP AROUND LABEL ACCEPTABLE.) THE UPPER EDGES OF THE LABELS SHOULD BE AS HIGH AS POSSIBLE UP TO 20 INCHES FROM THE BOTTOM OF CARTON.

CARTONS ON PALLET

EACH CARTON SHOULD BE INDIVIDUALLY LABELED AS DESCRIBED ABOVE. ONE MASTER LABEL MAY BE USED AS DESCRIBED IN SECTION 7.1, OR ONE MIXED LOAD LABEL AS DESCRIBED IN 7.2.

DRUMS, BARRELS, OR CYLINDRICAL CONTAINERS

IDENTICAL LABELS SHOULD BE LOCATED ON THE TOP AND NEAR THE CENTER OF THE SIDE.

BALES

IDENTICAL LABELS SHOULD BE LOCATED AT THE UPPER CORNER OF AN END AND THE ADJACENT SIDE. (WRAP AROUND LABEL ACCEPTABLE.)

EXHIBIT 7B

LABEL LOCATIONS ON VARIOUS SHIPPING PACKS

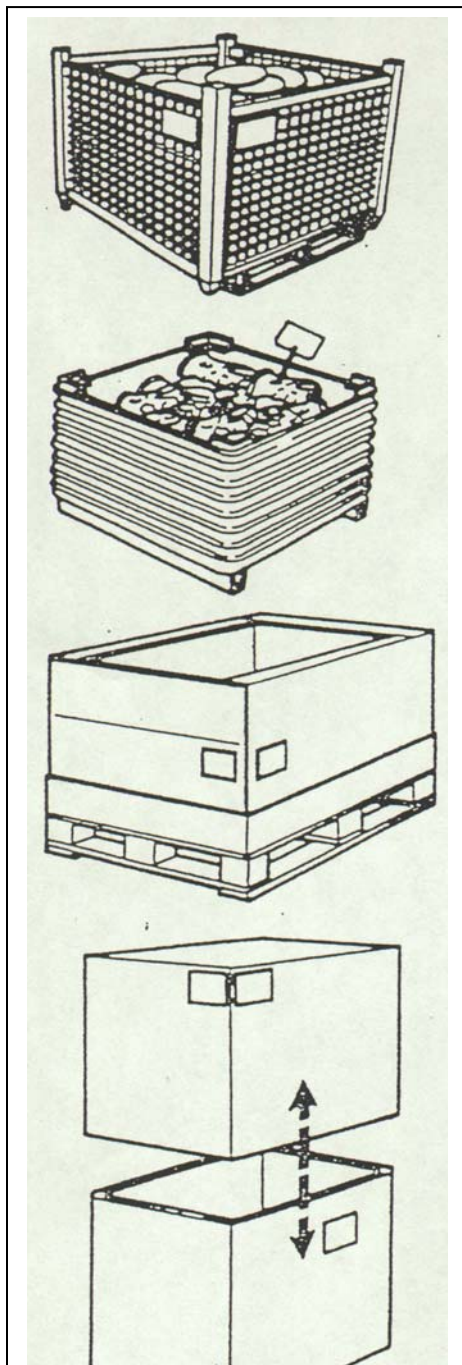

BASKET, WIRE MESH CONTAINER

IDENTICAL LABELS SHOULD BE LOCATED ON TWO ADJACENT SIDES.

METAL BIN OR TUB

TAG ONE VISIBLE PIECE NEAR TOP, OR USE A LABEL HOLDER.

PALLET BOX

IDENTICAL LABELS SHOULD BE LOCATED ON TWO ADJACENT SIDES. (WRAP AROUND LABEL ACCEPTABLE.)

TELESCOPIC OR SET-UP CONTAINERS

IDENTICAL LABELS SHOULD BE LOCATED ON TWO ADJACENT SIDES OF THE OUTER BOX. SOME APPLICATIONS MAY ALSO REQUIRE IDENTIFICATION OF THE INNER BOX.

EXHIBIT 7C

LABEL LOCATIONS ON VARIOUS SHIPPING PACKS

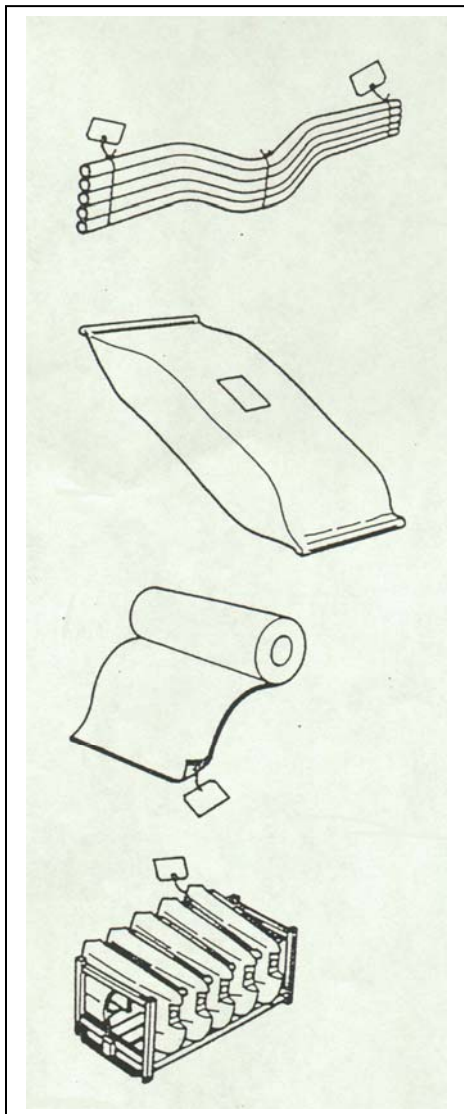

BUNDLE

IDENTICAL TAGS SHOULD BE LOCATED AT EACH END.

BAG

PLACE ONE LABEL AT THE CENTER OF FACE.

ROLL

HANG ONE TAG 2.0 IN. (51 MM) FROM END OF THE MATERIAL.

RACK

TAG ONE VISIBLE PIECE NEAR TOP, OR USE A LABEL HOLDER.